

## SWAGING FERRULE

The Swaging Ferrule is used to retain an Adjust-A-Jaw®, Adjust-A-Body® or a Fixed Jaw onto a piece of cable.

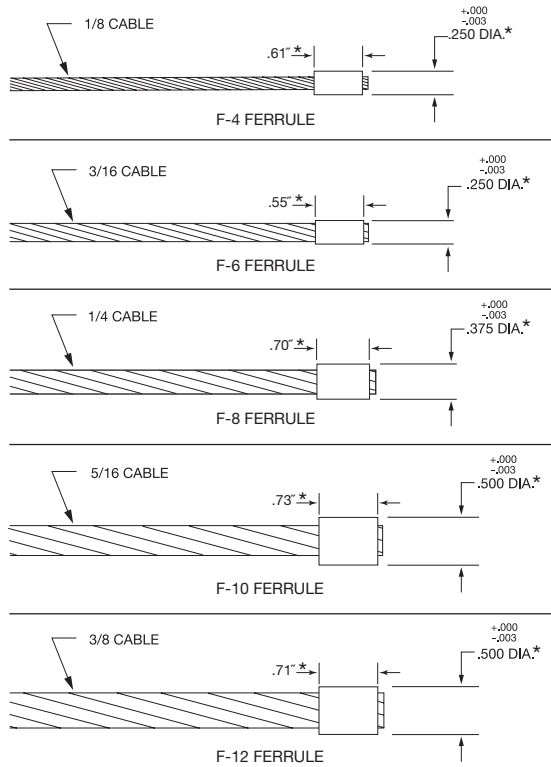

\*After swaging

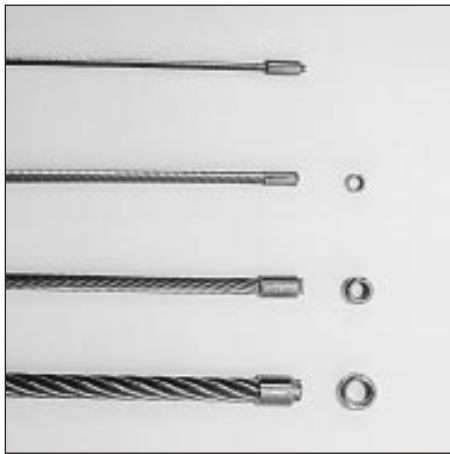

**MATERIAL: TYPE 316 STAINLESS STEEL**

## SWAGING STUD

The Swaging Stud is used in conjunction with an Invisiware® receiver or Welded Receiver. This fitting provides a means of tensioning a cable in as small an area as is feasible. The threaded surface of the stud is treated with a moly-based surface treatment that is baked on. This will prevent thread galling and sticking under extreme loads and environments.

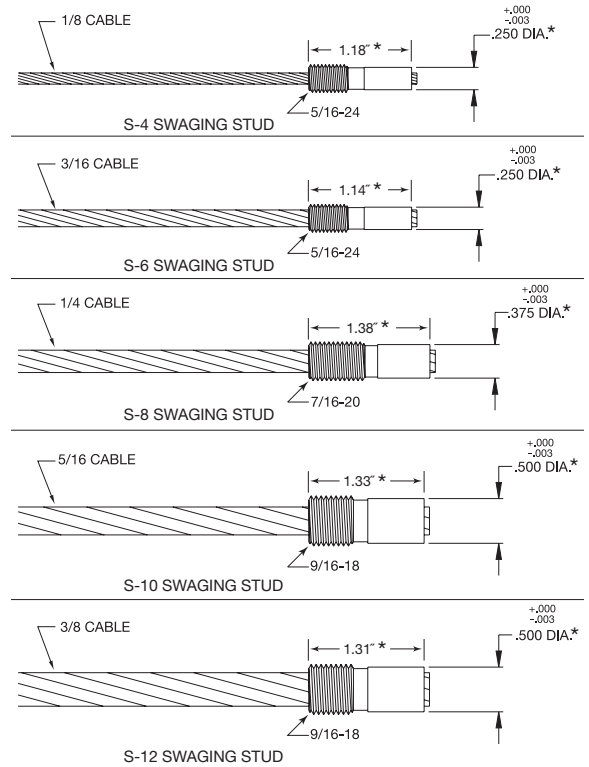

\*After swaging



**MATERIAL: TYPE 316 STAINLESS STEEL**

All Ultra-tec® hardware is manufactured in the United States of America.

1-800-851-2961 ■ 775-885-1443 ■ Fax 775-885-2734  
52 Heppner Drive ■ Carson City, NV 89706  
E-mail: info@ultra-tec.com Website: www.ultra-tec.com

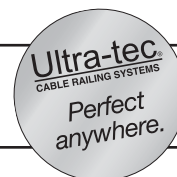

**Ultra-tec®**  
CABLE RAILING SYSTEMS