

PULL-LOCK™ STOP-END FITTINGS

Pull-Lock™ fittings are designed for use with 1x19 L.H. lay strand only. They can be used with any tensioning device on the other end...but **when used with our swageless tensioners, both ends can be put on the cable by hand** without any swaging or special tools.

You can order your cables with a tensioner already on one end or you can install a tensioner on one end on site. Attach the tensioner on one end post, slip the Pull-Lock™ fitting into the other end post and pull the cable all the way through the Pull-Lock™ fitting. Tension the cables, then cut the excess cable off on the back side of the fitting with a 4" right angle grinder or a cutting wheel (available from the factory) that is used with your hand drill. Press on the stainless steel cap to cover the bare cable end, and you're done!

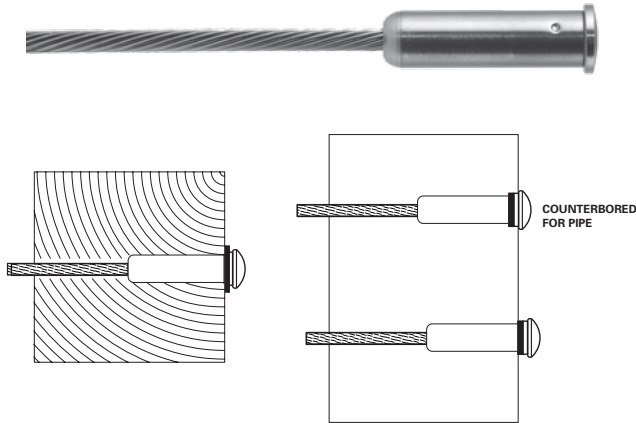

USE WITH METAL OR WOOD POSTS

Pull-Lock™ fittings are used with pipe and with round, square, or rectangular metal tubing. When used with an end post 1-1/2" or more in thickness, **the Pull-Lock™ fitting is hidden inside the end post**, with only the head exposed on the outside of the post. Pipe ends are counterbored, so the full perimeter of the screw cap head rests on a flat surface in the pipe. The head rests on the outside wall of a flat-sided metal post. A plastic washer is included and acts as a scratch-resistant barrier between the screw cap head and the metal post. For wood applications, also order 7/16SAE stainless steel washer.

BEVELED WASHERS

STAINLESS STEEL BEVELED WASHERS

FOR PITCH OF	ORDER PART NO.
30° - 33°	BW32-6
34° - 36°	BW35-6
37° - 39°	BW38-6

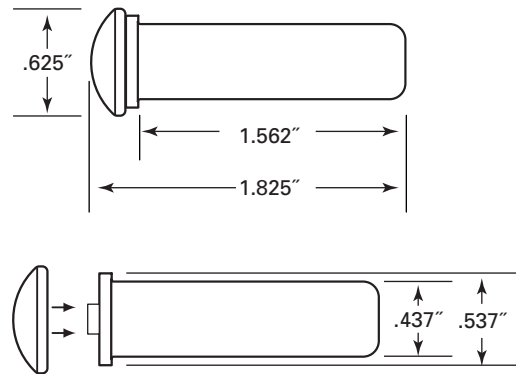

Pull-Lock™ fittings are made of type 316 stainless steel, with the exception of internal components that are made of other types of stainless steel.

DESIGNED FOR USE WITH 1X19 L.H. LAY STRAND ONLY

CABLE DIA.	FRAME OPTIONS		FOR WOOD, ALSO USE S.S. WASHER PART NO.
	1-1/2" TUBE or 1-1/4" PIPE	OTHER FRAMES	
1/8"	PUL-4-12*	PUL-4	7/16SAE

*For appearance, ends are flat (rather than rounded) on PUL-4-12 for use with 1-1/2" tubes and 1-1/4" pipe.