

INVISIWARE® RECEIVER

The Invisiware® receiver is designed to be used with our swaging stud. When the appropriate receiver is selected for a particular type and size of end post, the result is a tensioning mechanism that is hidden within the end post itself. Only the head area of the receiver will be exposed outside of the post. The head area is the domed shaped end of the receiver that is larger than the body of the receiver. It acts as a shoulder to support the tension of the cable as it is tightened. The outside of the domed head is broached with a hex broach to accept an Allen wrench to tension the cable.

Pipe end posts are counterbored to receive the head and to minimize its exposure on the outside of the post. On flat-sided end posts, the head rests flush against the surface of the post. The

Invisiware® receiver can be used on stair pitches up to approximately 35° without drilling end posts on an angle. We include a plastic washer to act as a scratch resistant barrier between the head of the receiver and the surface of the post.

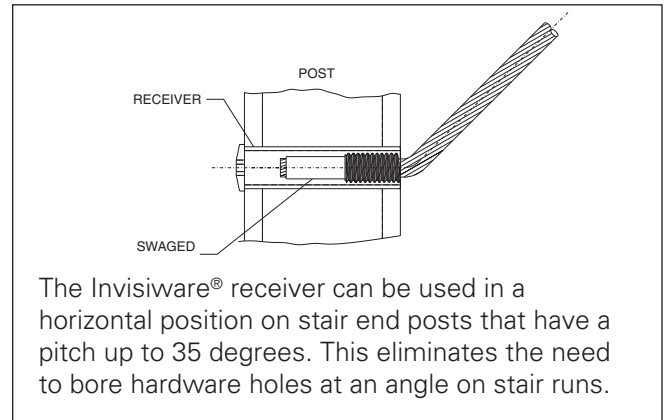
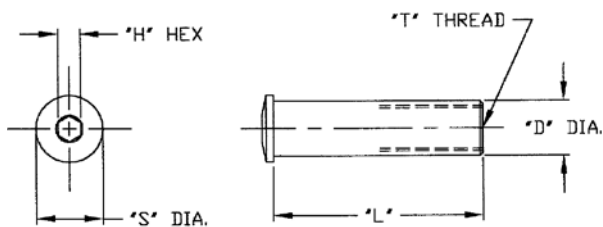
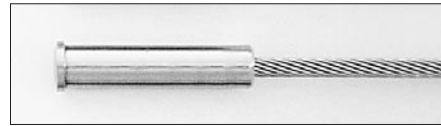

HOW IT WORKS

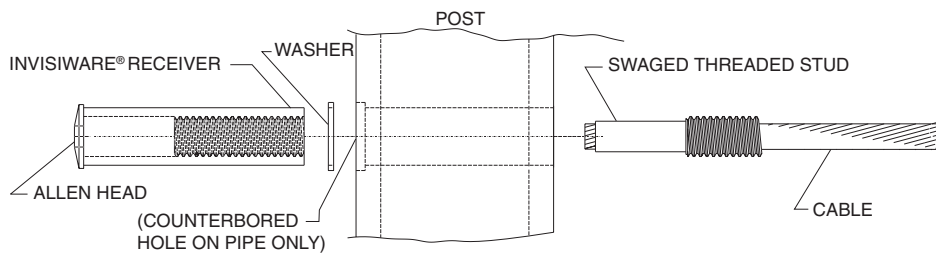

TYPE 316 STAINLESS STEEL

CABLE DIA.	USE WITH STUD NO.	DIMENSIONS	FRAME OPTIONS							
			1-1/2" TUBE or 1-1/4" PIPE	1-1/2" PIPE	2" x 2" TUBE	2-3/8" TUBE	2" PIPE	2-1/2" TUBE	3" X 1" TUBE or 2" X 1" TUBE	3-1/2" TUBE or 4" X 4" WOOD POST
1/8"	S-4	D = .437" H = 3/16" T = 5/16-24 S = .537"	R-6-12 L = 1.562"	R-6-22 L = 1.812"	R-6-32 L = 2.030"	R-6-72 L = 2.375"	R-6-42 L = 2.301"	R-6-82 L = 2.530"	R-6-52 L = 3.030"	R-6-62 L = 3.5625"
3/16"	S-6		—	R-8-22 L = 1.812"	R-8-32 L = 2.030"	—	R-8-42 L = 2.301"	—	R-8-52 L = 3.030"	—
1/4"	S-8	D = .531" H = 7/32" T = 7/16-20 S = .646"	—	R-8-22 L = 1.812"	R-8-32 L = 2.030"	—	R-8-42 L = 2.301"	—	R-8-52 L = 3.030"	—
5/16"	S-10	D = .687" H = 5/16" T = 9/16-18 S = .865"	—	—	R-12-32 L = 2.030"	—	R-12-42 L = 2.301"	—	R-12-52 L = 3.030"	—
3/8"	S-12		—	—	R-12-32 L = 2.030"	—	R-12-42 L = 2.301"	—	R-12-52 L = 3.030"	—

All Ultra-tec® hardware is manufactured in the United States of America.

1-800-851-2961 ■ 775-885-1443 ■ Fax 775-885-2734
52 Heppner Drive ■ Carson City, NV 89706
E-mail: info@ultra-tec.com Website: www.ultra-tec.com

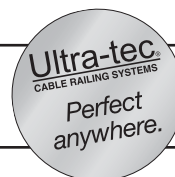

Ultra-tec®
CABLE RAILING SYSTEMS