

# INVISIWARE® RADIUS FERRULE

The Invisiware® radius ferrule is designed to be hidden within the end post. Only the head will be exposed outside of the post. The head area is a dome-shaped end that is larger than the body of the ferrule and acts as a shoulder to support the tension of the cable. The radius ferrule is swaged onto the end of the cable. It is not an adjuster. An Invisiware® receiver or Adjust-A-Jaw Tensioner should be used on the other end for adjustment.

Pipe end posts are counterbored to receive the head and to minimize its exposure on the outside of the post. On flat-sided end posts, the head rests flush against the surface of the post.

We include a plastic washer to act as a scratch resistant barrier between the head of the radius ferrule and the surface of the post.

**NOTE:** This part is designed for use on pipe and square tube railing only. It should not be specified for 3" x 1" and 2" x 1" double end post construction railings.

## HOW IT WORKS

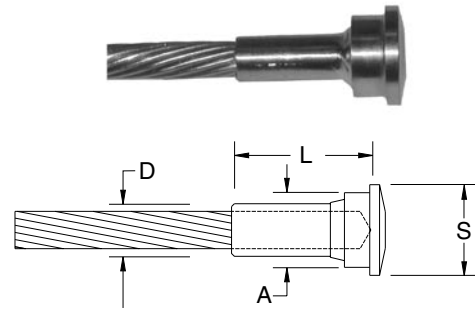
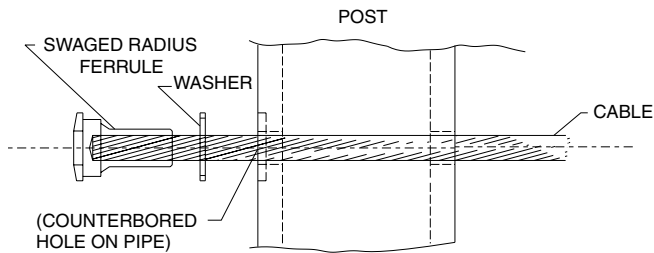

### TYPE 316 STAINLESS STEEL

CABLE DIA.	PART NUMBER	D DIAMETER (AFTER SWAGED)	L LENGTH SWAGED	S HEAD DIAMETER	A SHOULDER DIAMETER
1/8"	RF-4	.250"	.750"	.537"	.437"
3/16"	RF-6				
1/4"	RF-8	.375"	1.000"	.646"	.531"
5/16"	RF-10	.500"	1.000"	.865"	.687"
3/8"	RF-12				

**GREEN**

These products contain at least 65% recycled content, qualifying for LEED® credit.

2  
12/1/07

All Ultra-tec® hardware is manufactured in the United States of America.

**Ultra-tec**  
CABLE RAILING SYSTEMS

Ultra-tec  
CABLE RAILING SYSTEMS  
Perfect  
anywhere.

1-800-851-2961 ■ 775-885-1443 ■ Fax 775-885-2734

52 Heppner Drive ■ Carson City, NV 89706

E-mail: info@ultra-tec.com Website: www.ultra-tec.com